



**SPX20**

**STEREO SOURCE SELECTOR/PREAMPLIFIER**

# **OPERATION MANUAL**

	Page
<b>1. Introduction</b>	3
<b>2. Installation</b>	4
2.1 Inspection and un-packing	4
2.2 Operating environment	4
2.3 CE standards	4
2.4 Power requirements	4
2.5 Signal levels	5
2.6 External connections	6-7
<b>3. Warranty</b>	8
<b>4. Description of controls</b>	9-10
4.1 Inputs section	9
4.2 Outputs section	10
4.3 Headphones section	10
<b>5. Applications</b>	11
5.1 Using the SPX20	
<b>6. Circuit description</b>	13
<b>7. Specifications</b>	14

The SPX20 is a six input stereo source selector designed to extend the number of inputs and range of monitoring facilities available on a typical mixing console. However the SPX20 is suitable for a wide range of monitoring applications including tape dubbing, audio-visual and digital workstations and for installation in background music applications.

Each of the inputs on the SPX20 has a level trim with sufficient range to cope with +4dBu and -10dBV equipment and for balancing the levels between the different sources. Inputs are selected by momentary action buttons which also allow more than one input to be selected at a time. Multiple inputs are mixed (summed).

Two separate outputs with level controls and on-off switching provide a means of selecting and balancing levels between two types of monitor speakers or alternatively to add a 'monitor mix to studio' facility to your mixer. The outputs have relay switching which is delayed at power on to prevent annoying and potentially dangerous thumps and clicks reaching your monitor speakers. The output section also has an overall Balance control, Mono and Dim switching.

The SPX20 also has a built-in headphone amplifier with separate level control and front panel accessible connector.

Main features of the SPX20 include -

- Six stereo inputs with level adjustment
- Momentary action input select with led indicators
- Front panel accessible insert and level adjust for Input 1
- Mixing of multiple input selects
- Balanced and unbalanced inputs on XLR, 1/4" TRS jack and phono/RCA connectors
- Output Balance, Mono and Dim
- Two separate outputs with level control and on-off switching
- Power on-off output relays
- Tape record output
- Headphone output with level control

### **IMPORTANT: PLEASE READ THIS SECTION BEFORE USING THE SPX20**

#### **2.1 INSPECTION AND UNPACKING**

---

The SPX20 has been carefully packed at our factory in a carton designed to withstand handling in transit. Should the unit appear to have been damaged in transit notify your dealer immediately and do not discard any of the packing. The carton should contain -

- The SPX20 unit
- Power cord
- Operator Manual (this book)

#### **2.2 OPERATING ENVIRONMENT**

---

The SPX20 is designed to operate between 0 and 50°C (32-122°F) with relative humidity no more than 80%. Should the unit be installed in an equipment rack, ensure that the ambient temperature conforms to these levels.

#### **2.3 CE STANDARDS AND THE LOW VOLTAGE DIRECTIVE (LVD)**

---

The SPX20 has been designed to meet the latest Electromagnetic Compatibility (EMC) regulations. However we recommend you do not operate the unit close to strong emitters of electromagnetic radiation such as power transformers, motors, mobile telephones or radio transmitters.

The unit should only be connected to a power supply of the type described in 2.4 POWER REQUIREMENTS or as marked on the unit. The unit must be earthed for safe operation. Disconnect the mains supply before removing any cover.

#### **2.4 POWER REQUIREMENTS**

---

There is a mains fuse located inside the unit which is accessed by removing the cover. This fuse is for protection against unit faults and as such will not normally need replacing. If you think you have a power related problem please refer to your dealer.

The voltage and fuse rating have been factory set for -

230V	50mA	UK
220V	50mA	Republic of Korea
115V	100mA	North America

- **The correct voltage and fuse rating is indicated on the rear panel.**

- **Please check that your unit is correctly rated for the voltage in the country of operation.**

If the fuse requires changing at any time please ensure the correct fuse is fitted. An incorrect fuse could cause damage to the unit and may constitute a fire hazard.

If you carry your SPX20 from one country to another it is very important to ensure the voltage is compatible.

For your information the unit can be internally rewired for use in 230V, or 115V and 100V countries - contact your dealer for information. A special 220V, 60Hz version is available for the Republic of Korea.

The mains lead connections to the appliance are coloured in accordance with the following code:

<b>Green-and-Yellow</b>	<b>Earth</b>
<b>Blue</b>	<b>Neutral</b>
<b>Brown</b>	<b>Live</b>

- **WARNING: THIS APPLIANCE MUST BE EARTHED**

## 2.5 SIGNAL LEVELS

---

For input level ranges see 'TRIM' control in the Description of Controls section. The TRIM range allows the SPX20 to work with +4dBu and -10dBu equipment.

**IMPORTANT NOTE:** To ensure the best performance from the SPX20 it is important to adjust the input TRIM controls to give the correct operating levels within the unit.

*Signals in excess of +20dB will cause the unit to distort.*

## 2.6 EXTERNAL CONNECTIONS

---

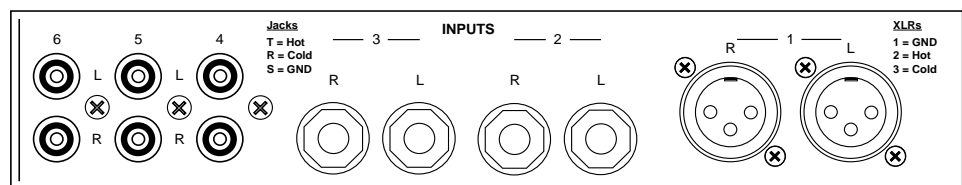

INPUTS section:

### INPUT 1

This input is balanced on XLR connectors and is wired as follows -

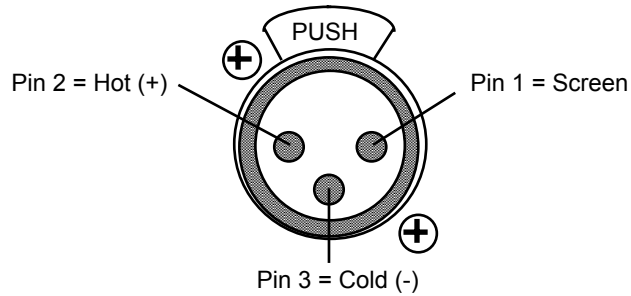

Fig 2.6.3: Pin arrangement for XLR inputs on the SPX20

Pin 1	Screen	Signal ground
Pin 2	Hot	Signal +
Pin 3	Cold	Signal -

For unbalanced operation join pins 1 and 3 and connect to Screen (signal ground) and use pin 2 as Hot (signal +).

Input 1 also has a pair of front panel inserts on TRS jacks which are wired as follows -

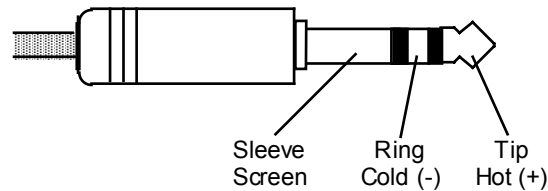

Fig 2.6.3: Pin arrangement TRS jack inserts on Input 1

Tip	Hot	Signal +
Ring	Cold	Signal -
Sleeve Screen	Signal ground	

For unbalanced operation join Ring and sleeve and connect to screen (signal ground) and use Tip as Hot (signal +).

*Plugging a mono jack into these inserts effectively unbalances the connection.*

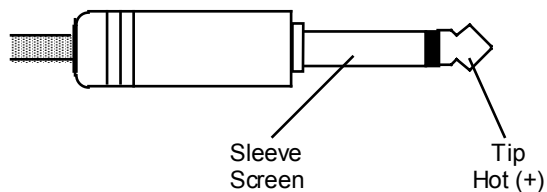

Fig 2.6.4: Mono jack pin arrangement

Tip	Hot (signal +)
Sleeve Screen	(signal ground)

*Plugging into the inserts jacks on the front panel breaks the signal from the rear panel XLRs*

### INPUT 2 & 3

These are balanced inputs on TRS jacks - see Fig 2.6.3

For unbalanced operation wire as described above for Input 1 inserts or use a mono jack plug.

### INPUT 4,5 & 6

These are all unbalanced inputs which have RCA/phono connectors. These are wired with the centre pin as hot (signal +) and the sleeve as screen (signal ground).

### TAPE RECORD

This is line level output of the selected input or inputs. Output level depends on the settings of the input TRIMs and on how many inputs are selected at the same time. If the input TRIMs are set up as described in the 'Description of Controls' sections then the level will be approximately 0dBu.

### OUTPUTS section:

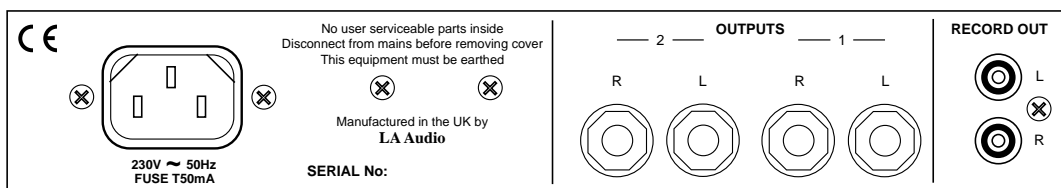

### OUTPUT 1 & 2

Outputs on the SPX20 are via 1/4" TRS jacks - see Fig 2.6.3

Tip	Hot	Signal +
Ring	Cold	Signal -
Sleeve Screen	Signal ground	

Output amplifiers on the SPX20 are 'ground compensated balanced impedance' type.

Your LA Audio SPX20 has been manufactured to a high standard using quality components. If correctly installed and operated the unit should give years of problem free operation.

However in the event of a defect in material or workmanship causing failure of the unit within one year of the date of original purchase we will agree to repair, or at our discretion replace, any defective item without charge for labour or parts. To receive service under this warranty it is necessary to return the unit to an LA Audio authorised service centre or to the factory with a dated receipt as proof of purchase. After repair the unit will be returned to you free of charge.

**Limitations:**

This warranty does not cover damage resulting from accident or misuse. The warranty is void unless repairs are carried out by an authorised service centre. The warranty is void if the unit has been modified other than at the manufacturers instruction. The warranty does not cover components which have a limited life, and which are expected to be periodically replaced for optimal performance. We do not warrant that the unit shall operate in any way other than as described in this manual.

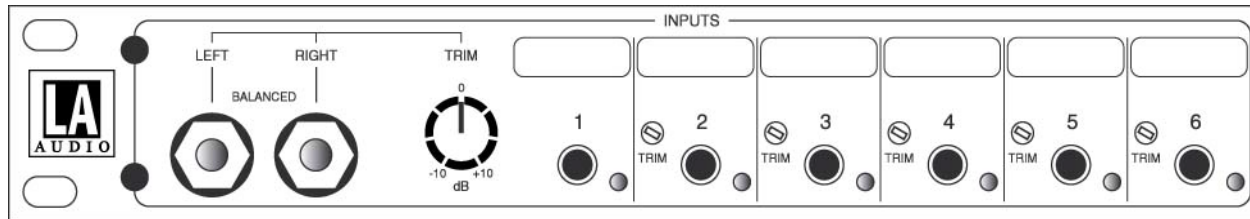

### 4.1 INPUTS SECTION

#### INPUT 1

##### Left & Right sockets

These are insert points for Input 1. Plugging into these connectors breaks the signal from Input 1's rear panel XLRs. They are intended to allow a quick and easy way of temporarily connecting an external piece of equipment to the SPX20.

##### TRIM control

The TRIM control for Input 1 has a range of  $\pm 10$ dB which should provide adequate adjustment for levels provided by pro, semi-pro and commercial equipment. The centre position (12 o'clock) provides unity gain (0dB) and has a mechanical detent for easy positioning.

##### 1 button

Pressing this switch selects Input 1 as the signal source. It is fed to the TAPE RECORD output, on the rear panel, OUTPUT 1 & 2 and the Headphone amplifier.

The associated led lights to show Input 1 selected.

##### 2, 3, 4, 5, 6 button

These select Inputs 2 through 6 as the Input source. Each select button has an associated led.

To select more than one input at the same time press and hold the first input and whilst holding this button press another button. It will be necessary to hold down all the inputs you want selected as each time a button is pressed it tries to cancel all other selections. Release all buttons.

##### TRIM control

Each input TRIM provides a gain range of -6dB (attenuation) at counter-clockwise (CCW) to +10dB clockwise (CW).

#### Setting up the SPX20

To ensure maximum headroom, noise and crosstalk performance it is important to have the correct signal levels within the SPX20. Please follow the following simple procedure.

When using equipment with a +4dBu output turn TRIM to almost CW and to fully CCW for -10dBV equipment as a starting point. Connect one of the outputs to your monitoring system and set LEVEL 1 or 2 control to give a suitable listening level. Then select each input in turn and adjust TRIM to give the same listening levels for each input. It should not be necessary to turn TRIM far from these settings.

## 4.2 OUTPUT SECTION

---

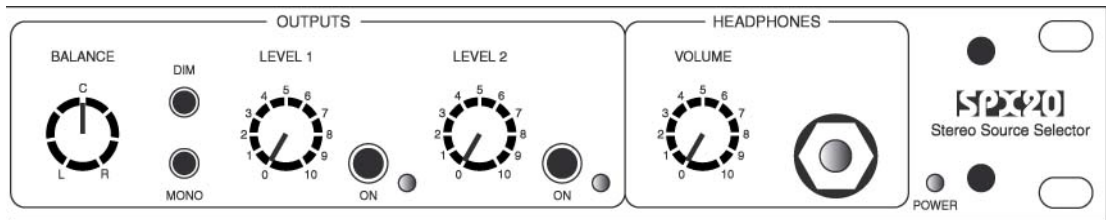

### **BALANCE** control

This control allows adjustment of the stereo centre position. The centre detent position gives equal left and right levels.

Turning BALANCE fully CCW cancels all right output signals and vice versa.

BALANCE affects OUTPUT 1 & 2 and Headphones.

### **DIM** switch

Pressing this switch in reduces output levels by 20dB.

DIM affects OUTPUT 1 & 2 and Headphones.

### **MONO** switch

Pressing the MONO switch sums left and right signals.

MONO affects OUTPUT 1 & 2 and Headphones.

### **LEVEL 1** control

This control adjusts the level of OUTPUT 1. Fully CCW is off and fully CW is +10dB. Unity gain (0dB) is around '7'.

### **ON** switch + led

Switches OUTPUT 1 on and off.

### **LEVEL 2** control

Similar to LEVEL 1

### **ON** switch + led

Similar to OUTPUT 1.

## 4.3 HEADPHONES SECTION

---

### **VOLUME** control

Controls the headphones signal level. Fully CCW is off.

The headphone amplifier on the SPX20 is designed to drive headphones with an impedance from 8Ω to 400Ω.

### **POWER** indicator

The green POWER indicator is lit whenever power is applied to the unit.

The majority of mixing consoles, even quite expensive models offer only 2 or possibly 3 monitoring inputs. So if you want to simultaneously connect a CD player, DAT machine, stereo cassette deck, 2 track analogue tape machine etc. you will have to use up input channels. These are often already used for tape returns or for FX so some repatching and gain adjustment will necessary in order to replay these sources.

The SPX20 has been designed to extend the number of monitor inputs and to offer some extra facilities not found on budget priced consoles. The SPX20 is intended to be used in one of two ways -

**5.1 AS THE MAIN MONITOR CONTROLLER**

In this application the SPX20 is used as the control centre for selecting sources and controlling levels in the monitors. Although this requires the SPX20 to be mounted in a readily accessible place it does offer a number of advantages -

The two separate outputs with on-off switching and level controls can be used to drive different types of monitor speakers.

Alternatively one output can be used for the control room monitors and the other provide a studio room feed.

The monitoring system benefits from the added protection of the delayed power-on and rapid power-off switching included in the SPX20.

A number of playback sources with different output levels can be balanced to provide a consistent listening level across all the inputs.

The TAPE RECORD output allows a stereo recorder to be connected to record a rough mix whilst laying down tracks.

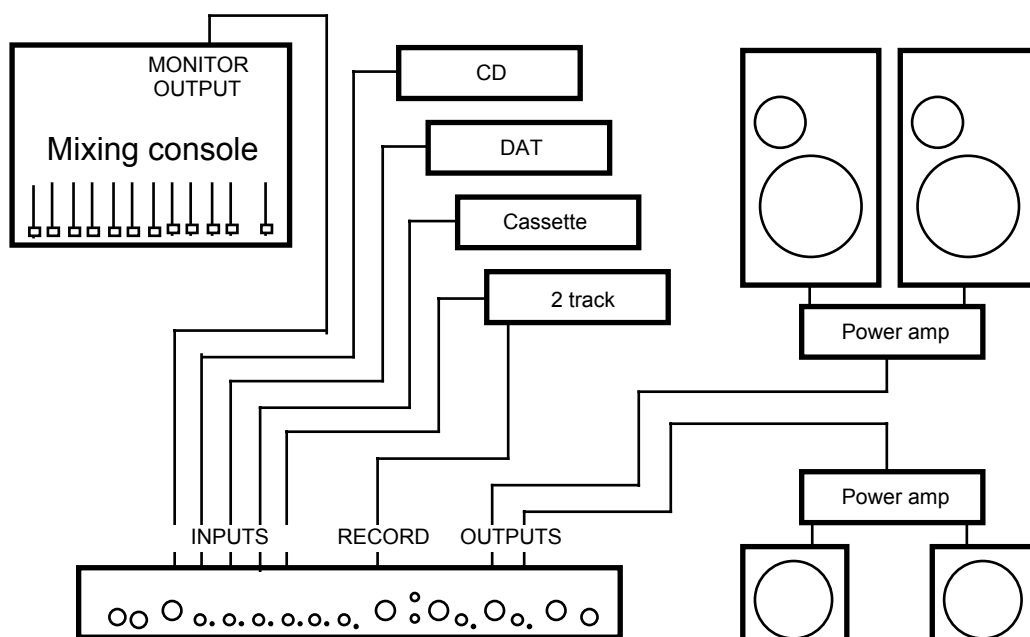

SPX20 Stereo source selector

Fig 5.1.1 Connecting the SPX20 as the main monitoring controller

## 5.2 AS A MONITOR EXTENDER

---

If you prefer to keep control of the control room monitors within the mixing console the SPX20 can be connected as shown in Fig 5.1.2. The SPX20 is now selected by pressing the 2T (2 track) return on the monitor section of the mixing console.

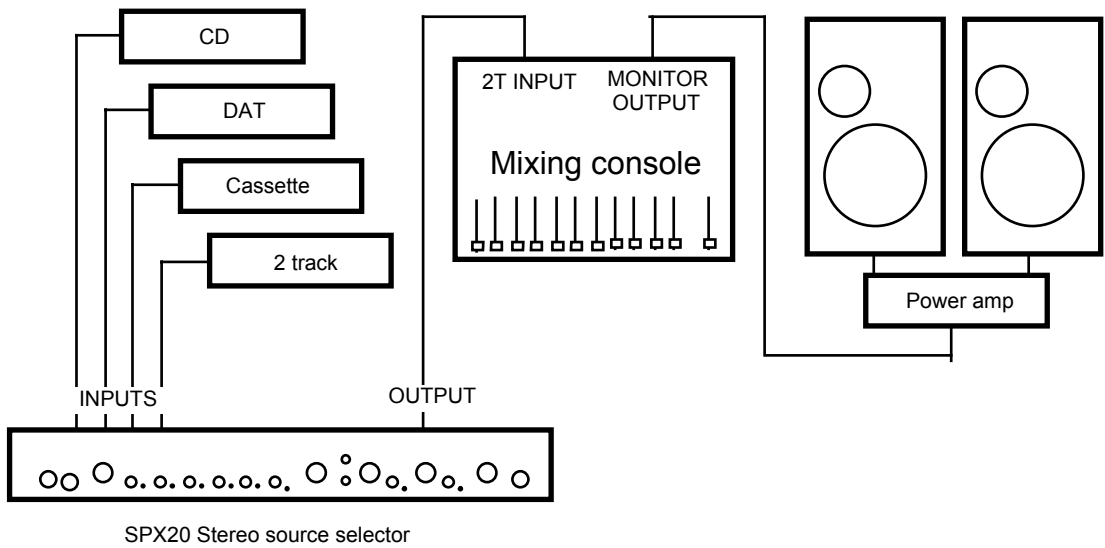

Fig 5.2.1 Connecting the SPX20 as a monitor extender

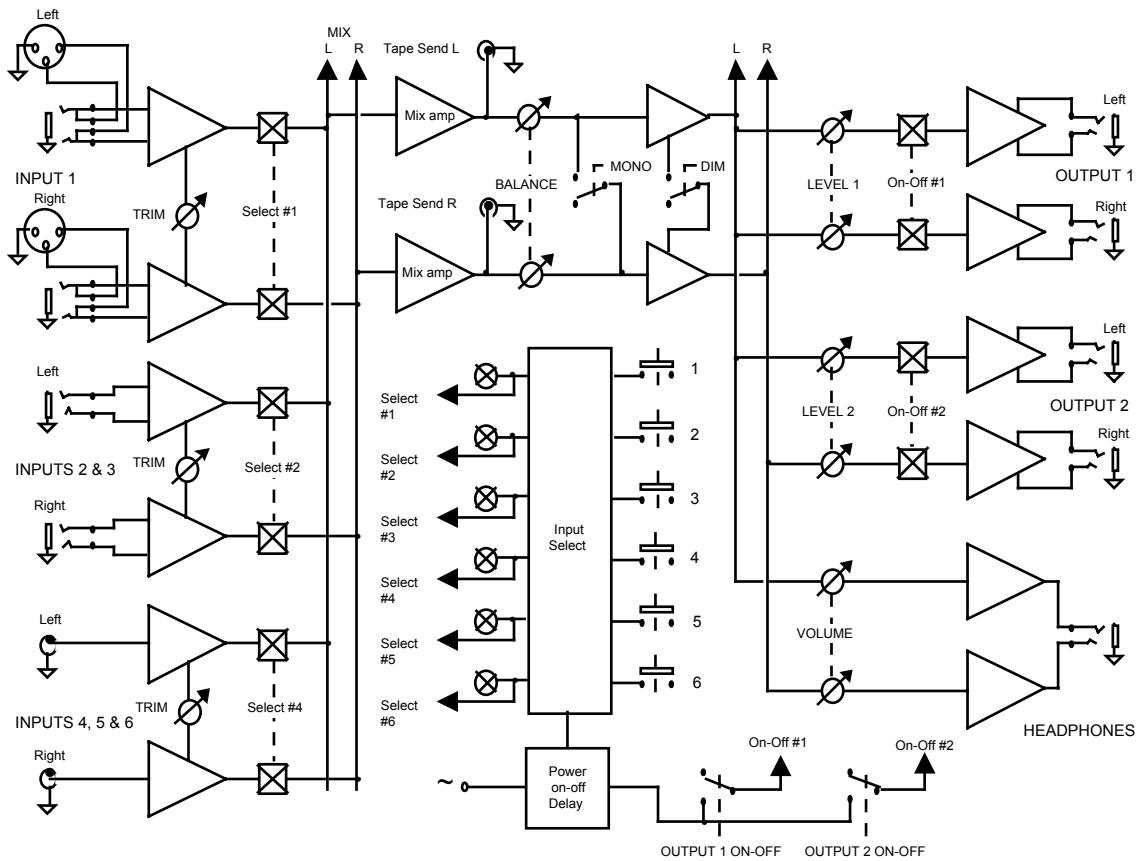

Fig 6.1.1 SPX20 block diagram showing main signal paths

**INPUT 1**

The input is routed through a pair of half normalised TRS jacks and into a differential amplifier. The TRIM varies the gain of the differential amplifier so ensuring maximum headroom at all gain settings. The output of this amplifier is fed via CMOS switches onto the mix buss.

**INPUT 2 & 3**

Inputs 2 and 3 are similar to Input 1 without the insert jacks.

**INPUT 4, 5 & 6**

These inputs are similar to Inputs 1-3 but are unbalanced.

The CMOS switches are controlled by the input select logic block. This consists of six set-reset latches. Pressing a select button sets its latch and sends a reset signal to all the other latches.

Signals on the mix buss are summed by two virtual earth amplifiers. These feed the TAPE RECORD output. The mixed signal also feeds the BALANCE pot, MONO and DIM switches.

OUTPUT 1 & 2 are relay switched. These relays are controlled by the OUTPUT on-off switches and the power on-off circuitry. The output amplifiers are configured as ground compensated, balanced impedance.

All inputs and outputs have RFI filtering.

## 7.0 SPECIFICATIONS

---

### INPUTS

---

1	electronically balanced, 20k $\Omega$ , XLR-F, pin 2 = hot
2 & 3	electronically balanced, 20k $\Omega$ , 1/4" TRS, Tip = hot
4, 5 & 6	unbalanced, 20k $\Omega$ , RCA/Phono, Centre pin = hot

### OUTPUTS

---

TAPE RECORD 100R, RCA/Phono, Centre pin = hot

#### OUTPUT 1 & 2

Type	Ground sensing, balanced impedance
1/4" TRS jack	0dBu (nominal), wired Tip = hot
Impedance	<100 $\Omega$
Max. output	+20dBu

### PERFORMANCE

---

THD+N	< 0.015%
Noise	<-90dBu, 20Hz to 20kHz
Frequency response	+0, -0.5dB, 20Hz to 20kHz
Crosstalk	<-70dBu @ 10kHz

### CONTROLS

---

TRIM 1	$\pm$ 10dB
TRIM 2 - 6	+10dB, -6dB
DIM	-20dB
LEVEL 1 & 2	$-\infty$ to +10dB

### POWER SUPPLY

---

Mains voltages	230Vac, 50Hz, 6VA	Europe
	115Vac, 60Hz, 6VA	North America
	220Vac, 60Hz, 6VA	ROK

Mains connector Standard IEC receptacle

### MECHANICAL

---

Dimensions	1.75" (44mm)H x 19" (482mm)W x 6.5" (165mm)D
Weight	Unit = 2.2kg, Shipping = 2.85kg