

PC80

Absolute Phase Checking System

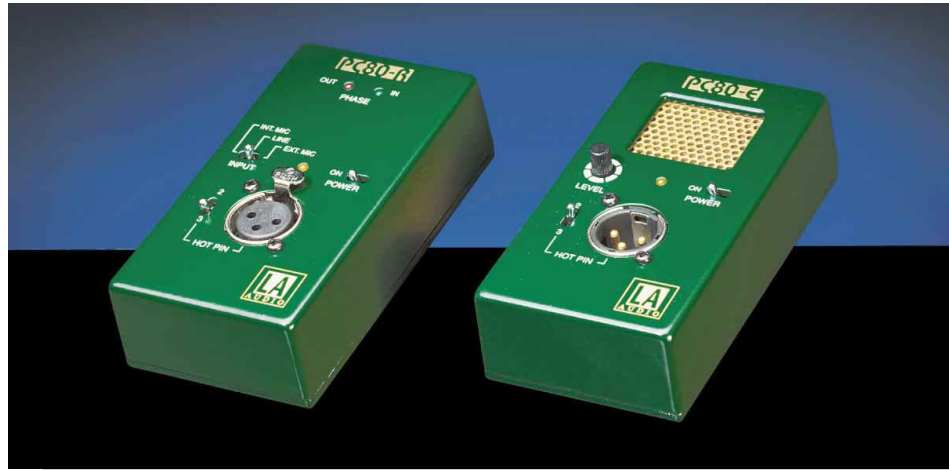

PRODUCT OVERVIEW

The PC80 is an advanced, highly portable phase measuring instrument that has been much copied, but never bettered. It was the first phase testing system to employ a wide band pulse to test absolute phase both acoustically and electrically. It can be used to measure the phase accuracy of any electronic audio system including microphones, loudspeakers and loudspeaker systems, mixing console patch points, patch bays and installation wiring.

The PC80 Generator emits a special 1Hz wide-band pulse via an integral speaker or XLR connector (with adjustable level control). This is read by the Receiver unit's internal, or externally connected microphone or XLR input. Two LED's show 'In' or 'Out' of phase. Pin swapping switches for the XLR connectors provide compensation for individual wiring practices.

The PC80 is an impressive time saver for the contractor, professional musician or recording studio.

SPECIFICATIONS

ELECTRICAL

| | |
|----------------------------------|--|
| Pulse rate: | 1Hz |
| Frequency response (electrical): | 1Hz - 20kHz (generator) 1Hz - 20kHz (receiver) |
| Frequency response (acoustic): | 200Hz - 5kHz (generator) 100Hz - 15kHz (receiver) |
| Output impedance: | 1R |
| Load impedance: | > 1R |
| Input impedance: | 1R (mic), 10R (line) |
| Output level: | 0 to 1Volt, XLR output only |
| Input level: | 10mV to 1V (mic) 0.5V to 50V (line) |
| Power requirement: | 9Volt battery PP3 10mA drain |

PHYSICAL

| | |
|--------------------|---|
| Connectors: | XLR 3 Pin |
| Temperature range: | |
| -Operating: | -10°C to +50°C |
| -Storage: | -40°C to +50°C |
| Dimensions (mm): | 113 (4.5") W 31 (1.25") D 60 (2.3") H |
| Weight: | 0.28kg, 0.62lbs (Generator) 0.25kg, 0.55lbs (Receiver) |
| Shipping weight: | 0.65kg, 1.43lbs (Including case) |



British Originals

In keeping with our policy of continuous improvement LA Audio reserves the right to alter specifications without prior notice. Manufactured in the UK by LA Audio, 6-24 Southgate Road, London, N1 3JJ. Tel: +44 (0)207 923 7447, FAX: +44 (0)207 241 3644. Web: www.laaudio.co.uk. email: sales@laaudio.co.uk
An SCV International Group Company

BLOCK DIAGRAM

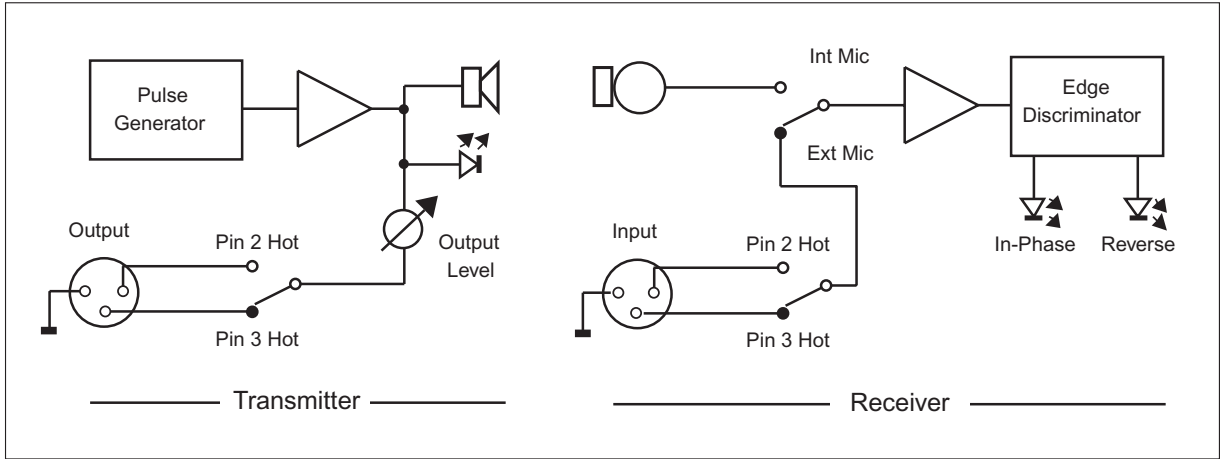

DIMENSIONS

