



PRODUCT OVERVIEW

Main Features:

- 12 Channel 1 into 4 (12 into 48) Active Mic Splitter
- Unique Input & Output configuration options
- Unity Gain signal path for ease of set-up
- Drives long cable runs without level loss
- Compact design, 48 channel System in 13U
- Channel Monitoring facility
- Individual input and Output group earth lift switches

The MS1224 is a 12 channel, 1 into 4 Unity Gain Active Microphone Splitter designed for applications where multiple feeds are required from one set of microphones without the signal degradation experienced with passive splitting solutions. The Unity Gain design principle combined with excellent line driving ability ensures that unity levels are delivered at the end of each feed, even over considerable distance, thereby saving time in recalibrating levels.

Each of the MS1224's channels has four independently buffered, transformer balanced outputs and a fifth dedicated parallel Link output. The Link output may be used to provide a direct, non active feed, for instance to the FOH console, or it can be used to daisy chain adjacent channels to provide more output feeds from a single microphone, for instance for Press Box applications. The inputs are electronically balanced with a Pad switch for connection of line level signals. Switchable Phantom Power is provided with a Phantom Presence LED.

The MS1224 incorporates a channel monitoring circuit, which is accessed on the PSU unit. Each channel has a Listen button that connects it momentarily both to an LED bargraph and headphone socket on the PSU front panel. The headphone monitor circuit incorporates a dynamics enhancement and protection system. This controls the dynamics of the signal in a way that amplifies very low background levels whilst limiting high signal levels. This enables monitoring of microphone function during set up without the need of a vocalist being present on the mic. It also provides user protection against sudden loud signals.

A unique design feature of the MS1224 is the option to configure the way that Input and Output connectors are presented on the front and rear of the unit. As each customer has their own views on this we have given the flexibility of presenting the Input and two Outputs on the front and three Outputs on the rear, or vice-versa. In addition the Output designated as Link can be positioned either below the Input connector, or the top connector of the group of three Outputs. Thereby giving four possible permutations. The required configuration can be specified ex-works or simply reconfigured at a later stage.

Each XLR connector on each channel is equipped with 3 pin moxex connectors for wiring to a multicore set. A standard rear panel multicore plate is available for use with 56 way EDAC connectors. Thereby up to four connectors per channel can be accessed via a multicore cable.

In keeping with our policy of continuous improvement LA Audio reserves the right to alter specifications without prior notice. Manufactured in the UK by LA Audio, 40 Chigwell Lane, Loughton, Essex, IG10 3NY.

Tel: +44 (0)208 418 0778, FAX: +44 (0)208 418 0624. Web: www.laaudio.co.uk. email: sales@laaudio.co.uk

An SCV International Group Company

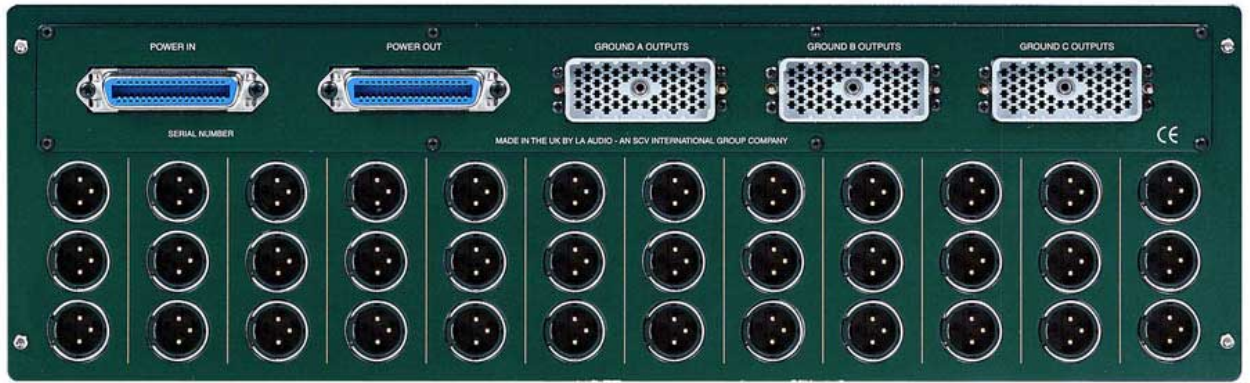
MS1224**12 Channel Unity Gain Mic Splitter with Monitor Bus**

CHANNEL BLOCK DIAGRAM

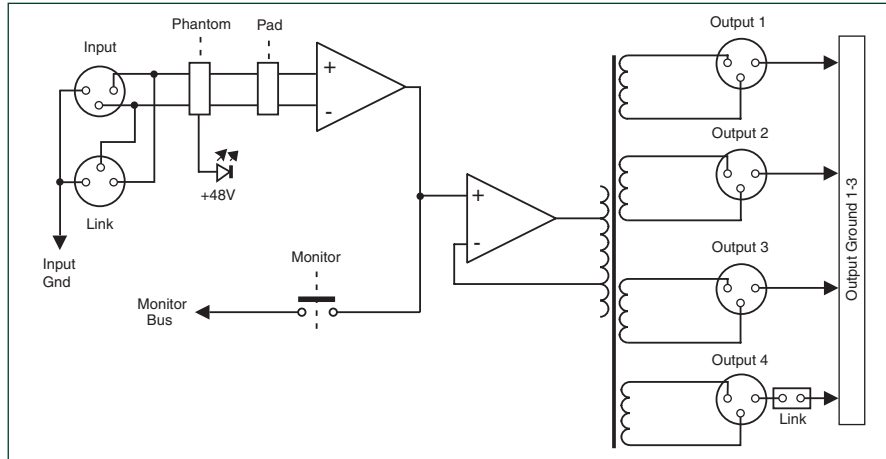

SPECIFICATIONS

ELECTRICAL

Frequency response: 20Hz - 20kHz, +0, -0.5dB
 Input Impedance: 2k
 Maximum Input Level: 0dBu (+20dBu with Pad)

Output Impedance: < 2R
 Load Impedance: >150R
 Gain: 0dB (-20dB with Pad)

Equivalent Input Noise: -122dBu
 THD: < 0.01%,
 1kHz, 150R load

Bargraph Calibration: -60dB to +20dB

Headphone Output: 2 x 0.125W, 8R - 600R
 Power Requirement: $\pm 17V$ bipolar, +48V

PHYSICAL

Input Connector: XLR 3 Pin (Pin 2 hot)
 Output Connector: XLR 3 Pin (Pin 2 hot)
 Interconnection: 34 way centronics cable
 Multiway option: 56 pin EDAC

Dimensions (mm): 483 (19") W
 225 (8.85") D
 133 (5.25") H (3U)

Weight: 5.5kg (12.1lbs)
 Shipping Weight: 6.1kg (13.4lbs)

Temperature Range: Operating: 0°C to 50°C
 Storage: -30°C to 75°C

EXTERNAL PSU

Power connection: Detachable lead
 IEC 3 pin socket

Dimensions (mm): 483 (19") W
 225 (8.85") D
 44 (1.75") H (1U)

Weight: 3.5kg (7.7lbs)
 Shipping Weight: 4.1kg (9.02lbs)

Power Requirement: 190VA,
 115/230V AC, 50/60Hz



British
 Originals

In keeping with our policy of continuous improvement LA Audio reserves the right to alter specifications without prior notice. Manufactured in the UK by LA Audio, 40 Chigwell Lane, Loughton, Essex, IG10 3NY, UK.
 Tel: +44 (0)208 418 0778, FAX: +44 (0)208 418 0624. Web: www.laaudio.co.uk. email: sales@laaudio.co.uk
An SCV International Group Company

ARCHITECTS & ENGINEERS SPECIFICATIONS

The Microphone Splitter shall be an active Unity Gain design offering 12 channels of 1 into 4 signal splitting. All four main feeds shall be fully floating transformer balanced. A dedicated direct Link output shall also be provided.

Each channel shall incorporate switchable Phantom Power with a Phantom Presence LED, and a Pad switch shall provide 20dB of attenuation for Line level compatibility. A monitor switch on each channel shall provide monitoring of the input signal via the Power Supply Unit which shall output both an audio signal via a headphones socket and visual indication via a 10 segment LED bargraph.

Access to the Input, Link and four Outputs shall be facilitated on interchangeable front and rear panel XLR connectors and all connections shall be available via multipin connector options on the rear of the unit. The Microphone Splitter shall be expandable by daisy chaining and shall be externally powered by PSU's capable of power sharing. The Microphone Splitter shall be the LA Audio MS1224.

DIMENSIONS

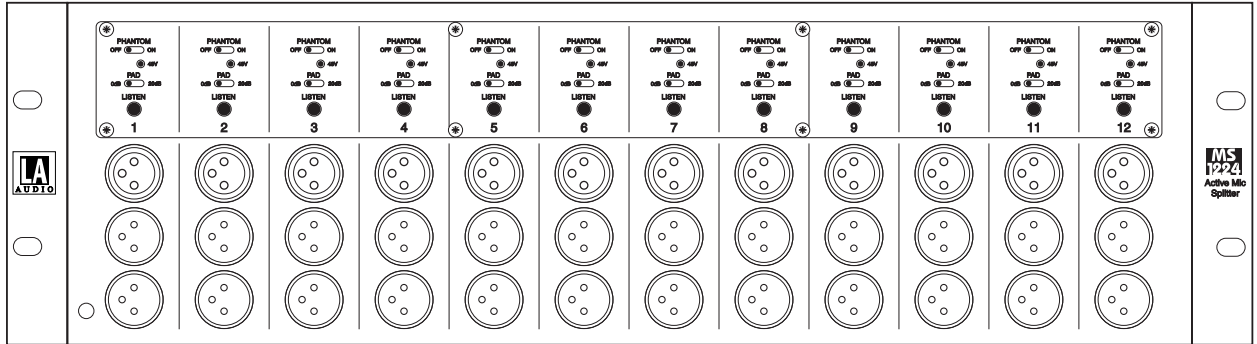

483.0

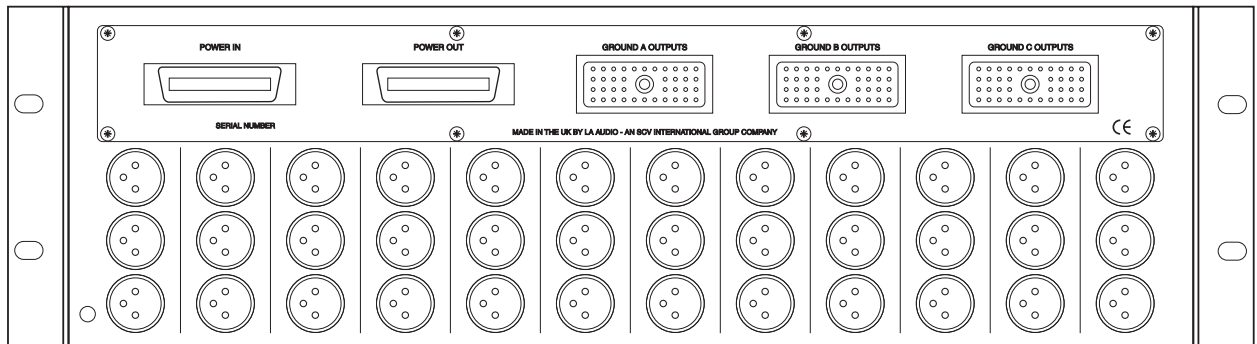
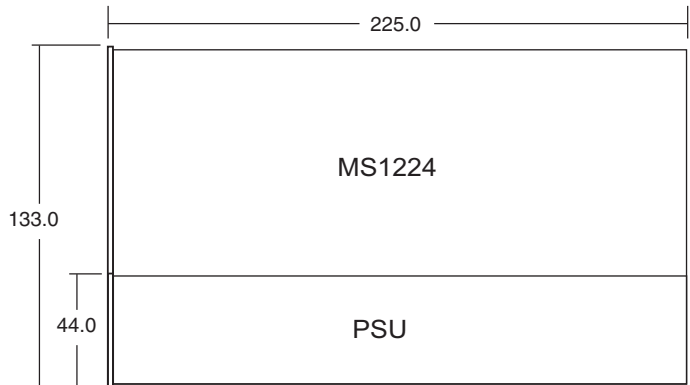
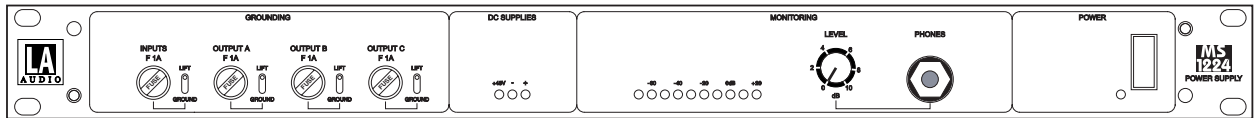

442.0

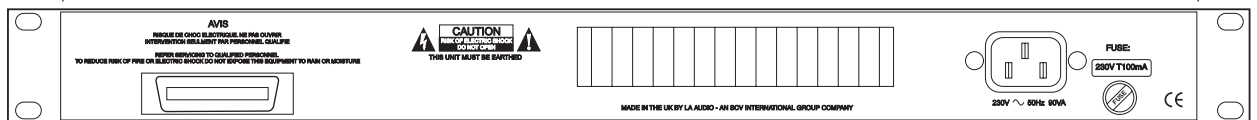

In keeping with our policy of continuous improvement LA Audio reserves the right to alter specifications without prior notice. Manufactured in the UK by LA Audio, 40 Chigwell Lane, Loughton, Essex, IG10 3NY, UK. Tel: +44 (0)208 418 0778, FAX: +44 (0)208 418 0624. Web: www.laaudio.co.uk. email: sales@laaudio.co.uk
An SCV International Group Company