

# MLX20

## Dual Mic/Line Preamp with DI Input



### PRODUCT OVERVIEW

The MLX20 is a professional two channel Mic Preamplifier which also accepts Line levels and Direct Instrument connection.

The unit is designed around an ultra low noise input device with excellent common mode rejection resulting in signal amplification of exceptional clarity. The DI input circuit is FET based producing excellent sonic characteristics especially on bass instruments.

Front panel controls include Input Gain, Variable High Pass Filter and Output level control. Front panel switches provide selection between the rear panel Mic and Line inputs and the front panel DI socket. Phase Reverse and +48V Phantom Power switches are also included.

### APPLICATIONS

The high degree of specification and performance the MLX20 offers makes it the ideal preamplifier for direct to analogue or digital recording of Mic, Line and Instrument sources.

The MLX 20 may also be used as a high quality active Dual DI unit.

### SPECIFICATIONS

#### ELECTRICAL

Frequency response:	±1dB, 20Hz to 20kHz
Mic input impedance:	1.2k balanced
Line Input impedance:	20k balanced
DI impedance:	0.5M
Output impedance:	<100R ground sensing
Output levels:	+4dBu on XLR -10dBV on TRS jack
Max output level:	+20dBu
Peak indicator:	3dB before clipping
Signal to Noise ratio:	Mic EIN <-128dBu Line <-90dB (at 0dB gain) DI <-80dB (at 20dB gain)
Gain:	Mic = +10dB to +60dB Line = -10dB to +30dB DI = 0dB to +30dB
Hi Pass Filter:	25Hz - 250Hz, -12dB/octave
THD:	< 0.05%
Power Consumption:	7VA, 115/230V, 50/60Hz
<b>PHYSICAL</b>	
Input connectors:	Mic: 3 pin XLR (Pin 2 hot) Line: 0" TRS jack (Tip hot) DI: 0" jack
Output connectors:	3 pin XLR (Pin 2 hot) 0" TRS jack (Tip hot)
Power Connection:	Detachable Lead, 3 pin IEC socket
Dimensions:	483mm (19") W 150mm (6") D 44mm (1.75")
Weight:	2.2kg
Shipping weight:	2.85kg



British  
Originals

In keeping with our policy of continuous improvement LA Audio reserves the right to alter specifications without prior notice. Manufactured in the UK by LA Audio, 6-24 Southgate Road, London, N1 3JJ.  
Tel: +44 (0)207 923 7447, FAX: +44 (0)207 241 3644. Web: [www.laaudio.co.uk](http://www.laaudio.co.uk). email: [sales@laaudio.co.uk](mailto:sales@laaudio.co.uk)  
**An SCV International Group Company**

### BLOCK DIAGRAM

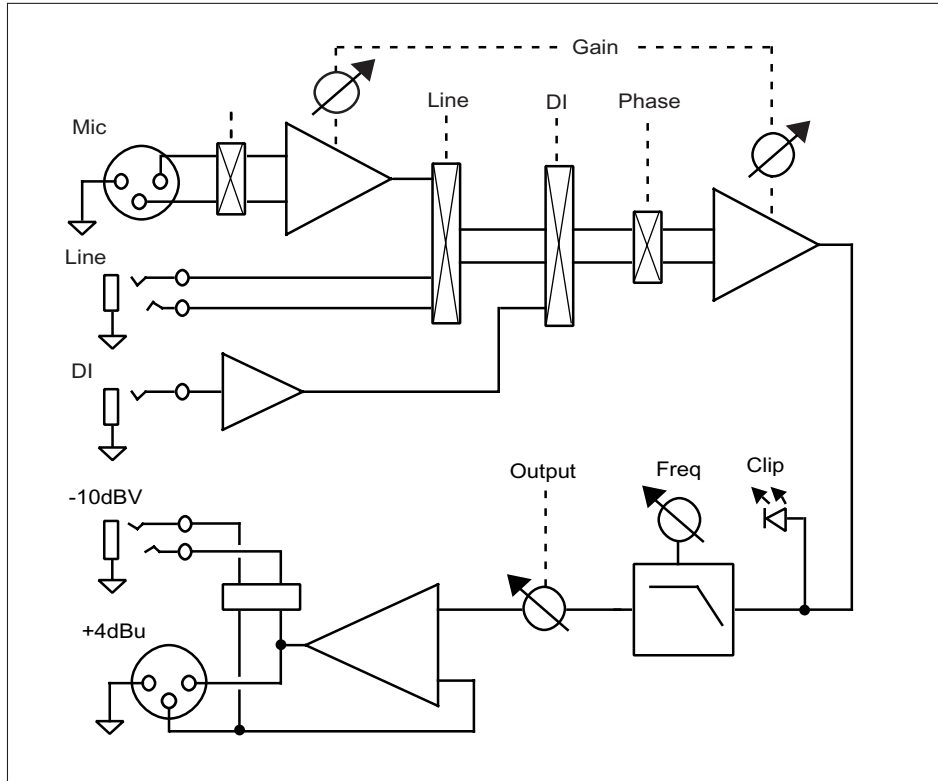

### DIMENSIONS

